

1.5 TON XB DUMP TRAILER

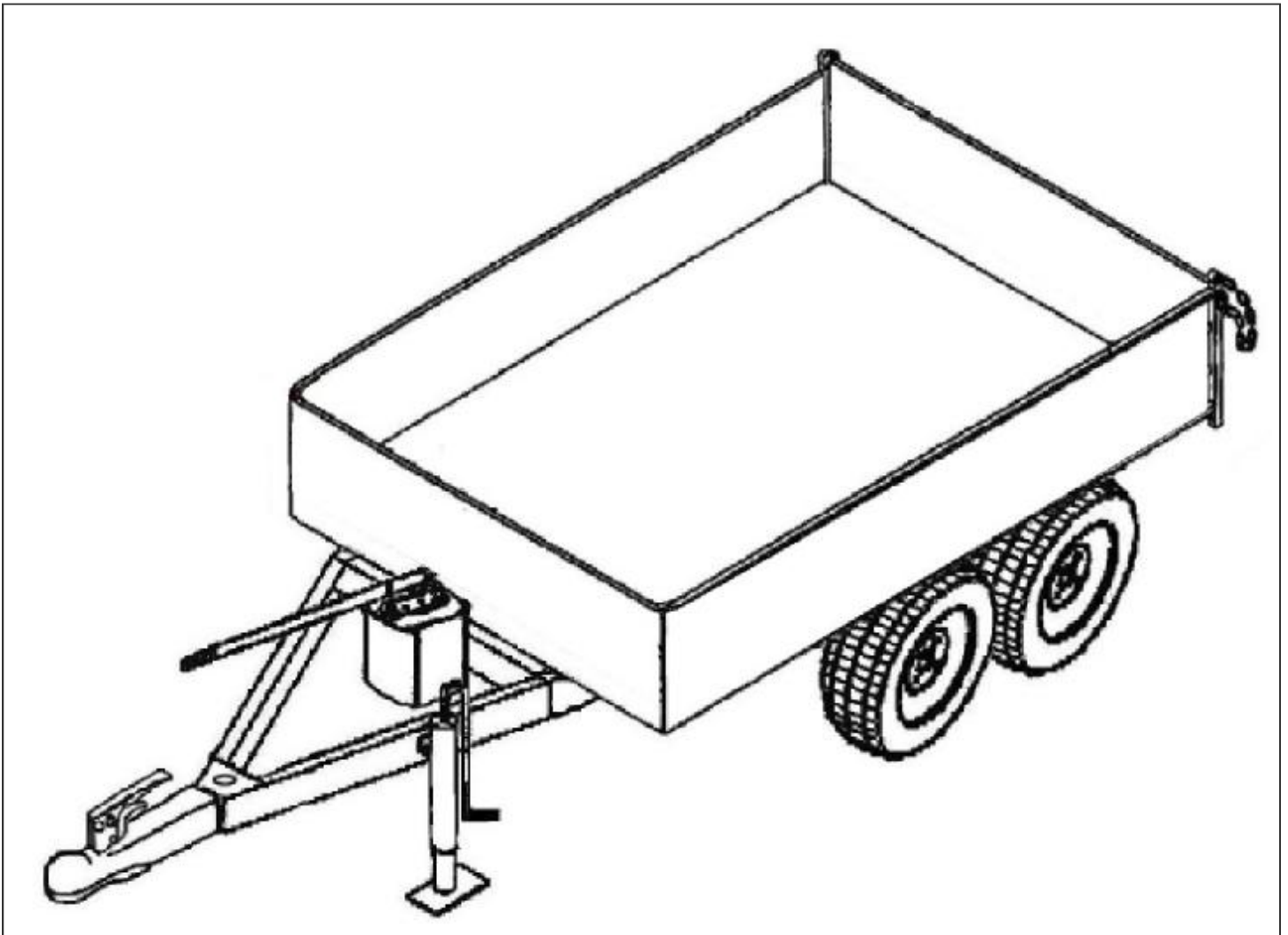

TO THE PURCHASER

This manual contains valuable information about your new King Kutter XB Dump Trailer. It has been carefully prepared to give you helpful suggestions for operating, adjusting, servicing and ordering repair parts.

Keep this manual in a convenient place for quick and easy reference. Study it carefully. You have purchased a dependable and sturdy dump trailer, but only by proper care and operation can you expect to receive the service and long life designed and built into it.

Sometime in the future your dump trailer may need new parts to replace those that are worn or broken. If so, go to your dealer and provide him with the model and part number.

Customer Information

Name _____

Purchased From _____

Date Purchased _____

Model No. _____

Serial No. _____

It is the purchaser and/or operator's responsibility to....

- I Read and understand the information contained in this manual.**
- I Operate, lubricate, assemble and maintain the equipment in accordance with all instructions and safety procedures in this manual.**
- I Inspect the equipment and replace or repair any parts that are damaged or worn which under continued operation would cause damage, wear to other parts, or cause a safety hazard.**
- I Return the equipment or parts to the authorized King Kutter dealer, from where it was purchased, for service or replacement of defective parts that are covered by warranty. (The King Kutter Factory may inspect equipment or parts before warranty claims are honored.)**
- I Payment of all costs incurred by the dealer for traveling to or transporting the equipment for warranty inspection and or claims.**

CONTENTS

ITEM	PAGE
Safety	6
Assembly Instructions	8
Maintenance	8
Attaching to Vehicle	8
Maintenance Safety.....	9
Storage and Storage Safety	9
Safety Training	10
Transport Safety	11
Operational Safety.....	12
Safety Decals	13
Replacement Parts.....	16
Tire & Wheel Replacement Parts	18
Dump Trailer Specifications.....	19
Warranty	20

READ AND FOLLOW THE INSTRUCTIONS IN THIS MANUAL AND ESPECIALLY IN THE SAFETY SECTION. FAILURE TO DO SO CAN RESULT IN SERIOUS INJURY OR DEATH.

TAKE NOTE! THIS SAFETY ALERT SYMBOL FOUND THROUGHOUT THIS MANUAL IS USED TO CALL YOUR ATTENTION TO INSTRUCTIONS INVOLVING YOUR PERSONAL SAFETY AND THE SAFETY OF OTHERS.



THIS SYMBOL MEANS
ATTENTION!
BECOME ALERT!
YOUR SAFETY IS INVOLVED

SIGNAL WORDS:

The signal words **DANGER**, **WARNING** and **CAUTION** are used with the safety messages in this manual and with each safety signs. They are defined as follows:

DANGER: Indicates an immediate hazardous situation that, if not avoided, could result in serious injury or death. This signal word is to be limited to the most extreme situations typically for machine components that, for functional purposes, cannot be guarded.

WARNING: Indicates a potentially hazardous situation that, if not avoided, could result in serious injury or death, and includes hazards that are exposed when guards are removed. It may also be used to alert against unsafe practices.

CAUTION: Indicates a potentially hazardous situation that, if not avoided, may result in minor or moderate injury. It may also be used to alert against unsafe practice.

If you have any questions not answered in this manual or require additional copies or the manual is damaged, please contact your dealer or King Kutter, Inc. P.O. Box 1200 Winfield, AL 35594 (205) 487-3202 or www.kingkutter.com

EQUIPMENT SAFETY GUIDELINES

- I Safety of the operator and bystanders is one of the main concerns in designing and developing a dump trailer. However, every year accidents occur which could have been avoided by a few seconds of thought and a more careful approach to handling equipment. You, the operator, can avoid many accidents by observing the following precautions and insist those working with you, or for you, follow them.
- I In order to provide a better view, certain photographs or illustrations in this manual may show an assembly with a safety shield removed. However, equipment should never be operated in this condition. Keep all shields in place. If shield removal becomes necessary for repairs, replace the shield prior to use.
- I Replace any safety sign that is not readable or is missing. An example of such safety signs is shown in this manual.
- I Never use alcoholic beverages or drugs that can hinder alertness or coordination while operating this equipment. Consult your doctor about operating this machine while taking prescription medications.
- I **Under no circumstances should children under the age of 18 be allowed to work with this equipment. Do not allow persons to operate or assemble this unit until they have read this manual and have developed a thorough understanding of the safety precautions and of how it works. Review the safety instructions with all users annually.**
- I This equipment is dangerous to children and persons unfamiliar with its operation. The operator should be a responsible, properly trained and physically able person familiar with farm machinery and trained in this equipment's operations. If the elderly are assisting with farm work, their physical limitations need to be recognized and accommodated.
- I Use a tractor equipped with a Roll Over Protective System and seat belts. (ROPS)
- I Never exceed the limits of a piece of machinery. If its ability to do a job, or to do so safely, is in question- **DON'T TRY IT.**
- I Do not modify the equipment in any way. Unauthorized modification could result in serious injury or death and may impair the function and life of the equipment.
- I In addition to the design and the confirmation of this implement, including safety signs and safety equipment, hazard control and accident prevention are dependent upon the awareness, concern, prudence, and proper training of personnel involved in the operation, transport, maintenance, and storage of the machine. Refer also to safety messages and operation instruction in each of the appropriate sections of the tractor and dump trailer manuals. Pay close attention to the safety signs affixed to the tractor and the dump trailer.

ASSEMBLY INSTRUCTIONS

Your XB - Dump Trailer is shipped fully assembled. Usually shipped with the ball hitch attached, the clevis hitch is bolted to frame under the front of the dump bed.

BEFORE OPERATING INSTRUCTIONS

- (1) Tighten all loose hardware. Replace any missing hardware. On new trailers, all hardware must be rechecked after first few hours of use.
- (2) Replace any broken or bent parts.
- (3) Check Trailer for signs of wear or damage. Replace parts if necessary.
- (4) Read the safety section of this manual to be sure of all precautions.

MAINTENANCE

- 1). Keep tires inflated to rated PSI (listed on tire) at all times.
- 2). Before each use check to make sure all safety features are installed and working properly.
- 3). Before each use check level of hydraulic fluid in hand pump, fluid should be half way in sight glass. (USE A GOOD GRADE OF HYDRAULIC FLUID)
- 4). Periodically check all nuts, bolts, jack, pump and hoses to insure they are tight and secure.
- 5). Make sure tailgate is shut and latched.

ATTACHING TO VEHICLE



WARNING

Never stand between
towing vehicle and dump trailer
while backing up
to connect the hitch.

STEP 1

Attach to tractor or towing vehicle's clevis or ball hitch and crank jack up.

STEP 2

If you have model with hoses hook them to tractor hydraulic remote outlets.



WARNING

Do not use bare hand to check for leaks. Hydraulic fluid under pressure can penetrate skin and cause poisoning.

MAINTENANCE SAFETY



- I Good maintenance is your responsibility. Poor maintenance is an invitation to trouble.
 - I Follow good shop practices.
 - I Keep service area clean and dry.
 - I Be sure electrical outlets and tools are properly grounded.
 - I Use adequate light for the job at hand.
- I Make sure there is plenty ventilation. Never operate the engine of the towing vehicle in a closed building. The exhaust fumes may cause asphyxiation.
- I Before working on this machine, shut off the engine, set the brakes, and remove the ignition keys.
- I Be certain all moving parts on attachments have come to a complete stop before attempting to perform maintenance.
- I Never work under equipment unless it is blocked securely.
- I Always use personal protection devices such as eye, hand and hearing protectors, when performing any service or maintenance.
- I Periodically tighten all bolts, nuts, and screws and check that all cotter pins are properly installed to ensure unit is in safe condition.
- I When completing a maintenance or service function, make sure all safety shields and devices are installed before placing unit in service.
- I After servicing, be sure all tools, parts and service equipment are removed from trailer.
- I Do not allow debris, grease or oil to build up on trailer.
- I Where replacement parts are necessary for periodic maintenance and servicing, genuine factory replacement parts must be used to restore your equipment to original specifications.
- I The manufacturer will not be responsible for injuries or damages caused by use of unapproved parts and/or accessories.
- I A fire extinguisher and the first aid kit should be kept readily accessible while performing maintenance on this equipment.

STORAGE & STORAGE SAFETY



- I Following operation, or when unhooking the trailer, stop the tractor, set the brakes, shut off the engine and remove the ignition keys.
- I Store the unit in an area away from human activity.
- I Do not park equipment where it can be exposed to direct contact to livestock for long periods of time. Trailer damage and livestock injury could result.
- I Make sure all parked machines are on a hard, level surface and engage all safety devices. Block to prevent rolling.
- I Clean all debris from trailer.

SAFETY TRAINING



- I Safety is a primary concern in the design and manufacture of our product. Unfortunately, our efforts to provide safe equipment can be wiped out by a single careless act of an operator or bystander.
- I In addition to the design and configuration of equipment, hazard control and accident prevention are dependent upon the awareness, concern, prudence and proper training of personnel involved in the operation, transport, maintenance and storage of this equipment.
- I It has been said, “ The best safety device is an informed, careful operator.” We ask you to be that kind of operator. It is the operator’s responsibility to read and understand all safety and operating instructions in the manual and to follow them. Accidents can be avoided.
- I Working with unfamiliar equipment can lead to careless injuries. Read this manual, and the manual for your tractor, before assembly or operating, to acquaint yourself with the machines. If this machine is used by any person other than you, or is loaned or rented, it is the dump trailer owner’s responsibility to make certain that owner’s manual be available to the operator prior to operating:
 - 1- Reads and understands the operator’s manuals.
 - 2- Is instructed in safe and proper use.
- I Know your controls and how to stop tractor, engine, and the trailer quickly in an emergency. Read this manual and the one provided with your tractor.
- I Train all new personnel and review instructions frequently with existing workers. Be certain only a properly trained and physically able person will operate the machinery. A person who has not read and understood all operating and safety instructions is not qualified to operate the machine. An untrained operator exposes himself and bystanders to possible serious injury or death. If the elderly are assisting with farm work, their physical limitations need to be recognized and accommodated.

PREPARATION



- I Never operate the tractor and trailer until you have read and completely understand this manual, the Tractor Operator's Manual, and each of the safety messages found on the safety signs on the tractor and trailer.
- I Personal protection equipment including hardhat, safety glasses, safety shoes, and gloves are recommended during assembly, installation, operation, adjustment, maintenance, repairing, removal, or moving the implement. Do not allow long hair, loose fitting clothing, or jewelry to be around equipment.
- I **PROLONGED EXPOSURE TO LOUD NOISE MAY CAUSE PERMANENT HEARING LOSS!** Tractors can often be noisy enough to cause permanent, partial hearing loss. We recommend that you wear hearing protection on a full-time basis if the noise in the operator's position exceeds 80 db. Noise over 80 db on a long-term basis can cause severe hearing loss. Noise over 90 db adjacent to the operator over a long-term basis may cause permanent, total hearing loss. **NOTE:** Hearing loss from loud noise (from tractors, chain saws, radios, and other such sources close to the ear) is cumulative over a lifetime without hope of natural recovery.
- I Operate the trailer only with a tractor equipped with an approved Roll-Over-Protective System (ROPS). Always wear your seat belt. Serious injury or even death could result from falling off the tractor — particularly during a turnover when the operator could be pinned under the ROPS or the tractor.
- I Operate only in daylight or good artificial light.
- I Ensure trailer is properly mounted, adjusted and in good operating condition.
- I Ensure that all safety shielding and safety signs are properly installed and in good condition.

TRANSPORT SAFETY



- I Use Slow Moving Vehicle (SMV) emblem and proper lighting on the tractor when transporting the trailer. **The dump trailer is made for off road use only! Do not transport on public roads.**
- I **Transport at no more than 20 MPH on best road conditions.** Reduce speed when going up and down hills and when approaching ditches or corners. Use care when transporting on rough terrain.
- I Watch for low hanging power lines during transport, contact can cause serious injury or death.
- I Always comply with all state and local lighting and marking requirements.
- I Keep your trailer in proper working condition. Unauthorized modifications to the trailer may impair the function, affect trailer life, and put you at risk. Do not add excessive weight to the trailer. Additional weight could cause the frame to fail resulting in loss of control of trailer and or tractor during transport.

OPERATIONAL SAFETY



- I Always stop the tractor, set brake, shut off the tractor engine, and remove the ignition key before dismounting tractor. Never leave equipment unattended with the tractor running.
- I Do not reach or place any part of your body under equipment until it is blocked securely.
- I Do not allow riders on the trailer or tractor at anytime. There is no safe place for any riders.
- I Do not operate unless all personnel, livestock, and pets are several feet away to prevent injury.
- I Never operate tractor and trailer under trees with low hanging limbs. Operators can be knocked off the tractor and then run over by the tractor or trailer.
- I Stop trailer and tractor immediately upon striking an obstruction. Turn engine off, remove key, inspect and repair any damage before resuming operation.
- I Stay alert for uneven terrain, holes, rocks, and roots and other hidden hazards. Keep away from drop-offs and hazards that could cause roll over. Use extreme care and maintain minimum ground speed when transporting or operating on hillsides, over rough ground and when operating close to ditches or fences. Be careful and slow down when turning sharp corners and changing direction on slopes. Do not start or stop suddenly on slopes. Avoid operation on steep slopes. In extremely uneven terrain, rear wheels weights, front tractor weight, and/or tire ballast should be used to improve stability.
- I Always check tractor manual for proper use on slopes.
- I When using a unit, a minimum 20% of tractor and equipment weight must be on tractor front wheels. Without this weight, tractor could tip over, causing personal injury or death. The weight may be attained with a front- end loader, front wheel weights, ballast in the tires or front tractor weights. When attaining a minimum 20% of tractor and equipment weight on the front wheels, you must not exceed the ROPS weight certification. Weigh the tractor and equipment. **Do not guess or estimate!**



SAFETY DECALS

ATTENTION! BECOME ALERT! YOUR SAFETY IS INVOLVED
Replace Immediately If Damaged

The following safety decals are located on your implement. Read them and follow their instructions. Keep all decals in place and legible. If safety signs have been damaged, removed, become illegible or parts have been replaced without signs, new safety signs must be applied. New safety signs are available from your authorized dealer, distributor or factory.

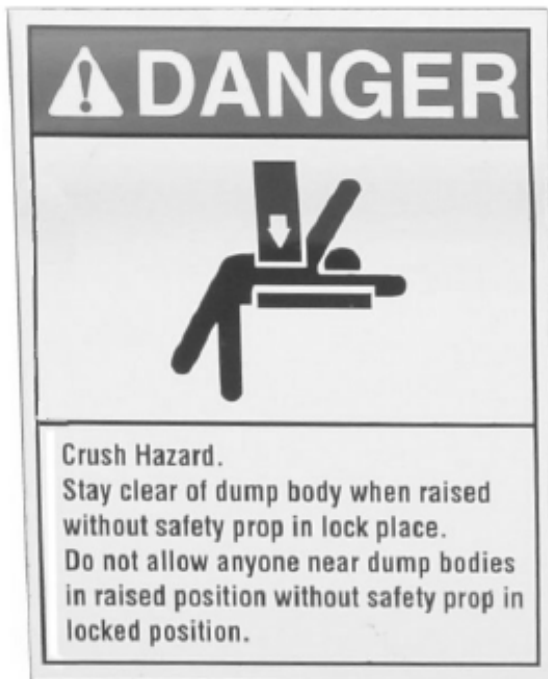

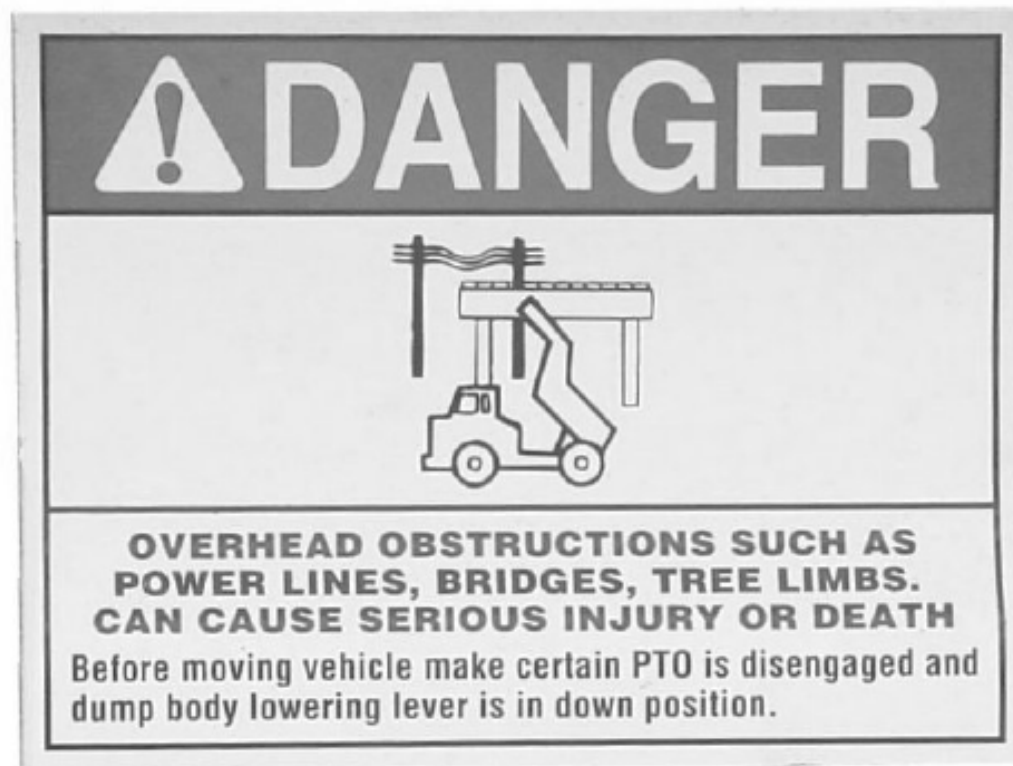

WARNING

FAILURE TO OBSERVE THE FOLLOWING COULD RESULT IN AN ACCIDENT, SERIOUS INJURY OR DEATH

Only a properly trained operator should operate the truck while using the dump body.

- * A daily inspection of bolts, welds, hinges and proper fluid level should be checked during the pre-trip and post-trip inspection.
- * Never raise the dump body on unlevel or soft terrain.
- * Before raising the dump body, check for overhead obstructions such as powerlines, tree limbs, buildings, etc.
- * The load on the dump body should always be distributed evenly.
- * Never raise the dump body in high gusty winds.
- * Due to weather and/or load material, a load may freeze or stick to dump body.
- * Never go outside of the vehicle while raising dump body.
- * Safety lock should be in locked position when dump body is raised for maintenance or servicing.
- * Never raise a loaded dump body for maintenance or servicing.
- * Before leaving the truck, always lower the dump body into it's original position.
- * When moving the truck, make sure the dump body is completely down and pto is in neutral.
- * Always release the tailgate before raising a loaded dump body.
- * Always make sure there is no one walking, standing or operating equipment in the area of operation.
- * Before operating this dump body, the operator needs to read and fully understand the operator's manual.

CAUTION

**Off Road Use Only!
DO NOT Exceed 20 MPH.**

XB - DUMP TRAILER

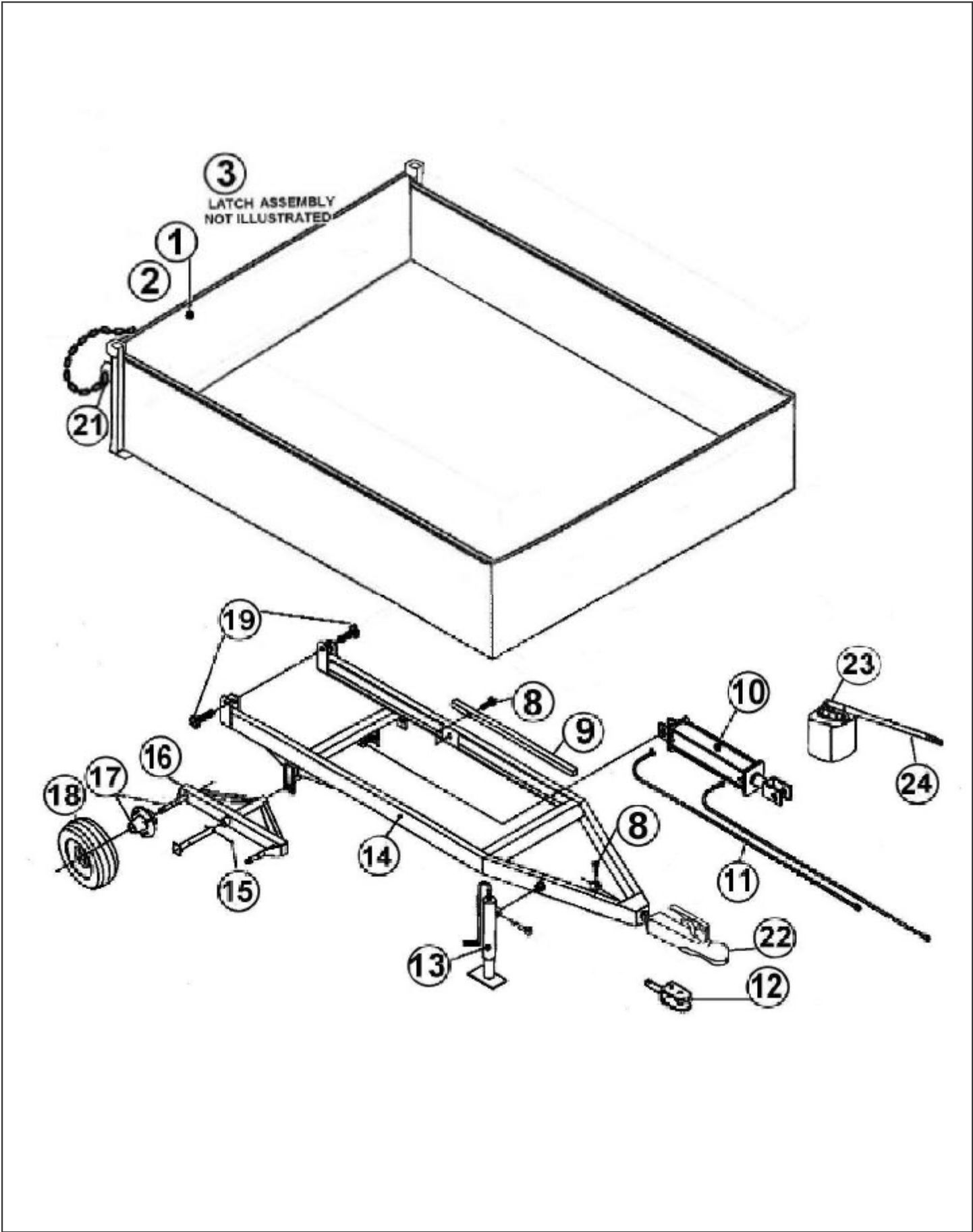

Ref. No.	Part Name	Part Number
1	Panel/Rear	906001
2	Bolt Pkg. HHS 3/8x 3/4 Gr. 5, 3/8 Flat Washer(4 ea.)	580100
3	Rear Panel Latch	NA
4	Panel/Left Side	NA
5	Bolt Pkg. HHS 3/8x 2 Gr. 5, 3/8 Locknut(8 ea.)	NA
6	Panel Front	NA
7	Floor Assembly	NA
8	Bolt Pkg. HHS 1/2 x 2-1/2 Gr. 5, 1/2 Locknut(2 ea.)	580120
9	Prop / Box	NA
10	Cyl / Hyd 3" x 12"	906100
11	Hose / Hyd 102"	906101
12	Swivel Clevis Hitch Pkg. (Hitch, Bolt, Bushing)	906005
13	Jack 10"	906007
14	Frame Trailer / Main	NA
15	Cotter Pin 5/32" x 3" (Pkg. 2)	580130
16	Frame Tandem / Pivot	906008
17	Hub / Wheel Assembly	906015 Next Page
18	Tire / Wheel Assembly	906018 Next page
19	Bolt Pkg. HHS 3/4 x 3-1/2 Gr. 5, 3/4 Hex Locknut(2 ea.)	580140
20	Panel / Right Side	NA
21	Chain (1/4" Zinc Plated)	NA
22	2" Ball Hitch Pkg. (Hitch, Bolt, Bushing)	906010
23	Manual Hydraulic Pump	906200
24	Lever/Handle Manual Pump	930544

1-1/2 TON TIRE & WHEEL HUB

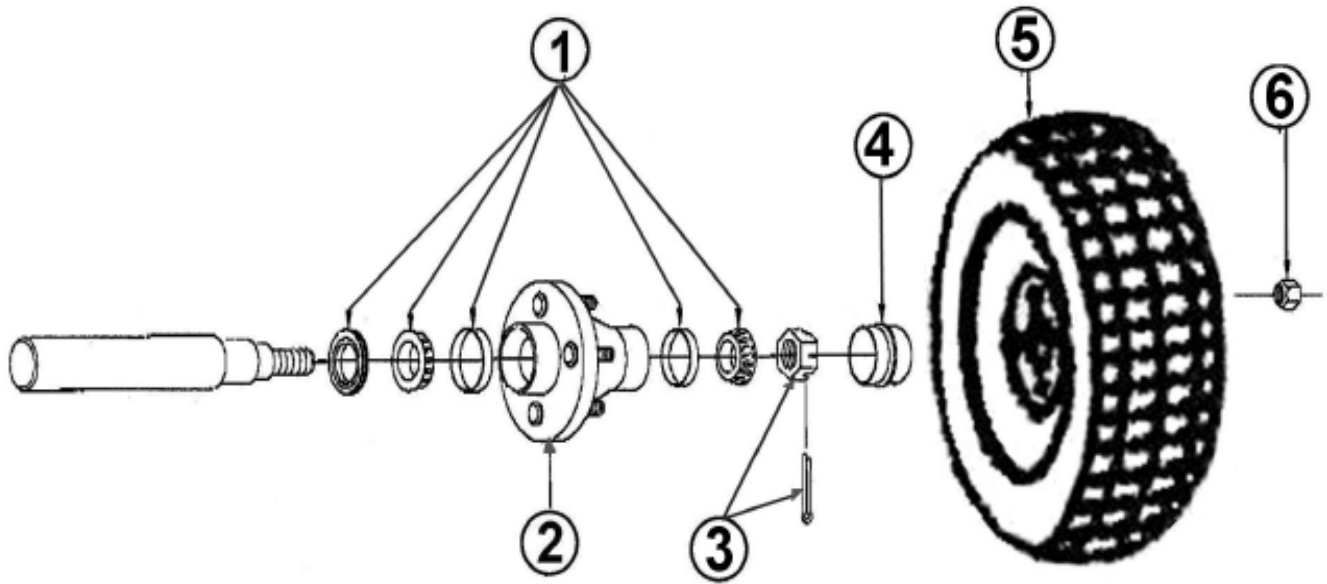

Ref. No.	Part Name	Part Number
1	Bearing Pkg. (1) Seal, (2) Bearings L44643, (2) L44610	906021
2	Hub Wheel 4-Bolt	906015
3	1" Slotted Hex Nut & Cotter Pin (5/32 x 1-1/4) Pkg.	906023
4	Cap Hub	906017
5	Rim & Tire 8.5 x 8 Turf Saver	906018
6	Lug nut 1/2" UNF (Pkg. 8)	906020

DUMP TRAILER SPECIFICATIONS

MODEL	1.5-DT-XB
CAPACITY-TON	1-1/2 TON
CAPACITY	35 CU. FT.
DUMP	REAR
HITCH	SWIVEL
AXLE	TANDEM
TIRE SIZE	18 X 8-1/2 X 8
NO. OF TIRES	4
WEIGHT	600 LBS.
BED WIDTH	50"
BED HEIGHT	21"
BED LENGTH	70"
BED FLOOR	12 GA.
OVERALL WIDTH	54"
OVERALL HEIGHT	34"
OVERALL LENGTH	8'6"
DUMP ANGLE	45 DEGREES
SIDE PANEL HEIGHT	13"
REAR PANEL HEIGHT	14"
FRONT PANEL HEIGHT	13"
TONGUE JACK	STD.



1. Limited Warranty.

King Kutter, Inc. ("King Kutter"), P.O. Box 1200, Winfield, Alabama 35594, warrants to the original retail purchaser ("Purchaser") that the product that is the subject of this sale is free from defects in material and workmanship at the time of sale.

Under this warranty, King Kutter will repair the defective product free of charge to the Purchaser, with either new or used and reconditioned replacement parts. All warranty service will be performed at service centers designated by King Kutter. If King Kutter is unable to repair the product to conform to the warranty after a reasonable number of attempts, King Kutter will provide, at its option, one of the following: (a) a replacement for the product or, (b) a full refund of the purchase price. Repair, replacement, or refunds are the Purchaser's EXCLUSIVE remedies against King Kutter under this limited warranty. King Kutter will not be liable for any special, incidental or consequential damages based upon breach or warranty, breach of contract, negligence, strict tort liability, or any other legal theory. Such damages include, but are not limited to, loss of profits, loss of savings or revenue, loss of use of the product or any associated equipment, cost of capital, cost of any substitute equipment, facilities or services, down time, the claims of third parties including customers, and injury to property. These limitations also apply, to the extent allowed by law, to personal injury.

The purchaser must notify the Seller in writing of any defect in material or workmanship within one (1) year following the date of purchase. If the equipment is used for commercial purposes, the Purchaser must notify the Seller in writing of any defect in material or workmanship within ninety (90) days following the date of purchase. In no event will King Kutter be liable under this warranty unless written notice is received by the Seller within one (1) year from the date of original retail sale.

2. Warranty of Title.

King Kutter warrants that it transfers a good title to the product free of any encumbrances, and free of the rightful claim of any third party for infringement of patent or copyright.

3. What is Not Covered by This Limited Warranty.

King Kutter will not be responsible for damage to or failure in the product which results from accident, misuse, abuse, neglect, installation of attachments not provided by King Kutter, modifications to the product, or damage caused by use of the product for purposes other than those for which it was designed.

4. No Other Warranties.

Unless modified in writing and signed by both parties, this agreement is understood to be the complete and exclusive agreement and warranty between King Kutter and Purchaser, superseding all prior agreements, oral and written, and all other communication between King Kutter and Purchaser related to the subject matter of this agreement.

THIS LIMITED WARRANTY IS IN LIEU OF ALL OTHER WARRANTIES, EXPRESS OR IMPLIED, INCLUDING, BUT NOT LIMITED TO, THE IMPLIED WARRANTY OF MERCHANTABILITY AND THE IMPLIED WARRANTY OF FITNESS FOR A PARTICULAR PURPOSE. No employee of King Kutter nor anyone else is authorized to make any warranty or representation in addition to or different from those made in this agreement.

5. Allocation of Risk.

This agreement allocates the risk of product failure between King Kutter and the Purchaser. This Allocation is recognized by both parties as reflected in the price of the goods. The Purchaser acknowledges that he or she has read this agreement, understands it, and is bound by its terms.